



JOB:
ITEM:
QTY:



CHILLTRAY DOLLY

APPLICATION:

These dollies are designed for heavy duty transporting and are ideal for cook-chill systems. These dollies will accept Nestier© and Buckhorn© chillpac containers 20" x 24".

MATERIAL:

Framework is constructed out of 1 1/2"x 2"x.070" wall tube with a 1" leg that creates the container stops.

CASTERS:

These dollies come equipped with four 5" platform type casters, two swivel and two rigid.

GUARANTEE:

These racks carry a **Lifetime Guarantee** against rust and corrosion and also carry a **Five-Year Guarantee** against workmanship and material defects.



Model #1171



Phone: 800-255-0104
Fax: 877-877-7687
www.newageindustrial.com
sales@newageindustrial.com

New Age Industrial reserves the right to modify or make changes at any time without notice to materials and specifications.

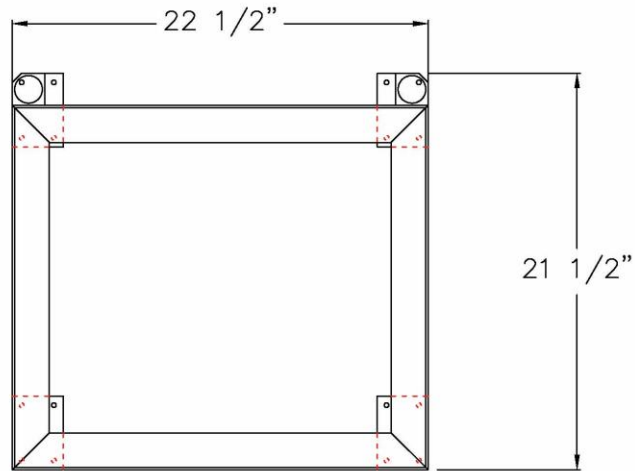
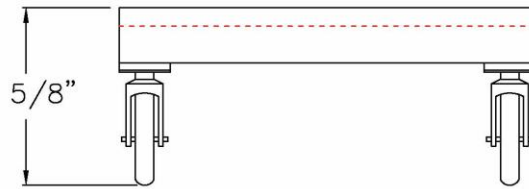

Model #1171

Model No.	Size-W	Size-L	Description
1171	22 1/2"	21 1/2"	Single Stack
1172	22 1/2"	42 1/2"	Double Stack
1174	Handle		



Phone: 800-255-0104
 Fax: 877-877-7687
www.newageindustrial.com
sales@newageindustrial.com

New Age Industrial reserves the right to modify or make changes at any time without notice to materials and specifications.