



JOB:  
ITEM:  
QTY:



# POLY BOX STORAGE RACK

## APPLICATION:

These racks are specifically designed to hold 18"x26" or 18"x13" poly food boxes. It also can hold poly boxes from many different manufactures such as Cambro, Carlisle, Continental, or Rubbermaid.

## MATERIAL:

Framework is constructed of 1"x1"x.070" wall tubing. Guides are constructed of 1"x1 1/2"x.085" channel. The channel allows storing the boxes with or without the lids.

## CASTERS:

These racks come equipped with four 5" platform type swivel casters.

## GUARANTEE:

These racks carry a **Lifetime Guarantee** against rust and corrosion and also carry a **Five-Year Guarantee** against workmanship and material defects.



**Model #1481**



Phone: 800-255-0104  
Fax: 877-877-7687  
[www.newageindustrial.com](http://www.newageindustrial.com)  
[sales@newageindustrial.com](mailto:sales@newageindustrial.com)

New Age Industrial reserves the right to modify or make changes at any time without notice to materials and specifications.

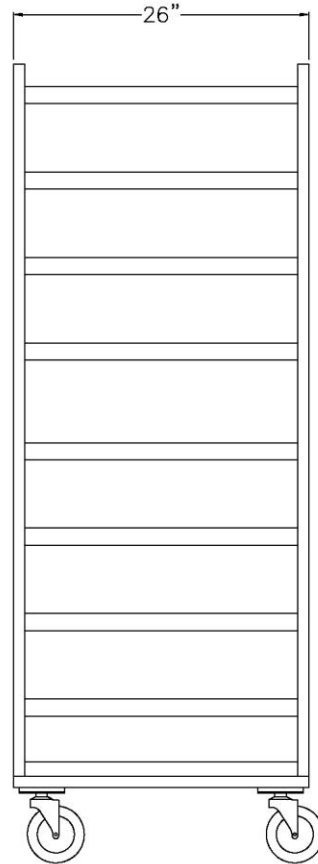
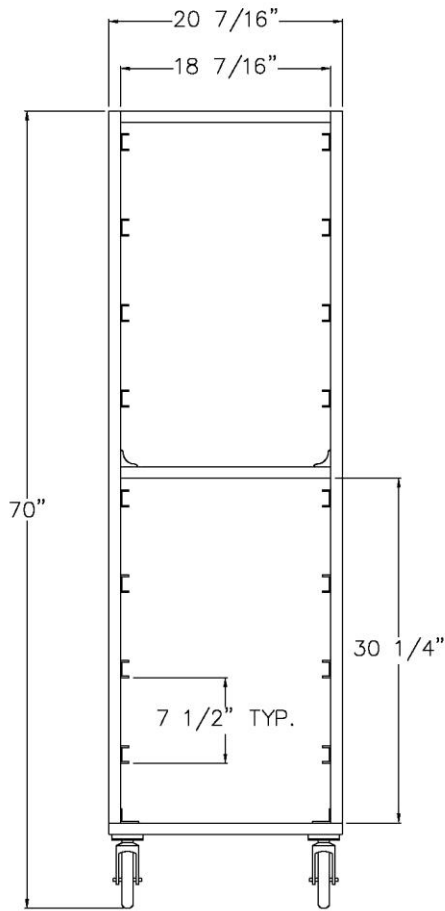

**Model #1481**

Model No.	Size-W	Size-H	Size-D	Runner Spac.	Pan Cap.
1481	20 7/16"	70"	26"	7 1/2"	8
NS648	20 7/16"	70 3/4"	26"	3 1/2"	16
92052	20 7/16"	71 3/4"	26"	5"	12

**THESE UNITS WILL NOT HOLD 18"X26" BUN PANS**



Phone: 800-255-0104  
 Fax: 877-877-7687  
[www.newageindustrial.com](http://www.newageindustrial.com)  
[sales@newageindustrial.com](mailto:sales@newageindustrial.com)

New Age Industrial reserves the right to modify or make changes at any time without notice to materials and specifications.