

Continental

Refrigerator

Operation, Installation and
Instruction Manual
for
Backbar, Keg & Bottle Coolers
And
Backbar, Glass & Plate Chillers

A Division of National Refrigeration & Air Conditioning Products, Inc.
539 Dunksferry Road • Bensalem, PA 19020-5908
215-244-1400 • 1-800-523-7138 • Fax: 215-244-9579
www.continentalrefrigerator.com

REV:09/2004

Operators Manual

Table Of Contents	Page
Receiving Your New Model	3
General Information And Important Operating Facts	3
Uncrating Your New Model	4
Installation And Location	4
Clearance.....	4
Ventilation.....	4
Floor Loads	5
Mounting Equipment In Place	5
Installing Legs And Leveling	5
Installing Casters And Leveling	7
Installing Condensate Evaporator	7
Initial Cleaning Procedure	8
Start-Up Procedure	8
Electrical Connections	8
115 Volt, 60 Hz, 1 Phase Connection	9
208-230 Volt, 60 Hz, 1 Phase Connection.....	9
Special Voltage Connections	9
Start-Up Checklist	9
Remote Applications	10
Operation	10
Refrigerator System And Adjustment	10
Evaporator Assembly	11
Interior And Exterior Accessories	11
Bottle Cap Catcher Installation	11
Wire Storage Bin Divider Installation.....	11
Keg Cooler Set-Up & Installation Instructions.....	12
Installation Of Towers And Cold Air Tubes	12
Installation Of CO ₂ Cylinder And Regulator	13
Keg Tapping Instructions.....	13
Safety Precautions	15
Maintenance	15
Periodic Cleaning Procedure	15
Precautions	16
General Preventative Maintenance.....	16
Parts And Service	16
Troubleshooting And Servicing Guide.....	18
Wiring Diagrams	21
Warranty	23

RECEIVING YOUR NEW MODEL

Congratulations on your recent purchase of continental refrigerator superior food equipment products! When your shipment arrives, please thoroughly examine the shipping crate for any punctures, dents, or signs of rough handling. It is in your best interest to partially remove or open the shipping container in order to examine the model for any concealed damages which may have occurred during shipment. If the model is damaged, it must be noted on the delivering carrier's delivery slip or bill of lading (see "filing a damage claim" under warranty section).

GENERAL INFORMATION AND IMPORTANT OPERATING FACTS

This manual has been compiled to aid in the installation, operation and maintenance of your new equipment. Please take the time to read all of the material in order to become more familiar with your equipment and its operation, and enjoy optimum performance.

No floor drains or plumbing connections are required since all models are completely self-defrosting and uses a non-electric, automatic defrost, condensate water evaporating system (see "condensate evaporator installation" under installation and location section). A clean out drainage hose has been provided behind the front grill for cabinet clean out convenience.

All cabinets must be given sufficient time to reach normal operating temperature before placing any product inside. Approximately 2 hours of operation are required to lower the cabinet temperature to 38°F (see "operation" section for further information). Freezers require approximately 3 hours of operation to lower the cabinet temperature to 5°F.

Prior to factory shipping, all models are performance run tested for a minimum of 12 hours providing a highly sophisticated temperature analysis recording exclusive to each individual cabinet. This recording is supplied within this manual packet. A final leak check, vibration, noise level and visual examination is made by a qualified quality control team to assure a quality product. The carrier signs to this effect when he accepts the product for shipping. To insure the maximum in safety and sanitation, all models are listed under the reexamination service of underwriter's laboratories and with the national sanitation foundation.

UNCRATING YOUR NEW MODEL

The shipping container should remain on your model as protection against dents or scratches while transporting it to the actual set-up location. Remove the shipping container only at the last possible moment by following these simple steps:

1. Using a pry bar, pry off and remove crate end bottom staples.
2. Pry off and remove crate front and rear bottom staples.
3. Slide crate upward and remove it, being careful not to rub against cabinet.

There are up to four (4) bolts securing the cabinet to the wooden skid. The bolts are located at each end on the underside of the skid. In order to remove these bolts it is advisable to tilt the cabinet backwards and place wooden blocks at each end in order to hold it in its tilted position. Using a $\frac{3}{4}$ " socket or open end wrench, remove the bolts and carefully slide the model off of the skid. After skid removal, the cabinet should never be moved without dollies or rollers to avoid damage to the cabinet bottom or floor.

Important Note: Do not under any circumstances lay your new model on its front or sides. Only for a brief period, may you lay the model on its back and only then, when it's properly blocked so as not to crush the condensate drain tubing and also to allow provision for your hands in order to set it in its upright position without inflicting damage to the cabinet. **Do not plug in and operate model for at least three (3) hours after cabinet is set upright from being on its back as damage could result to the compressor.**

INSTALLATION AND LOCATION

CLEARANCES

Before moving the cabinet to its final point of installation, accurately measure all doorways or passages to assure clearance. If additional clearance is needed, cabinet bumpers can be easily removed.

VENTILATION

The final location site of your air cooled, refrigerated bottle cooler must be able to provide a large quantity of cool, clean air. The refrigeration system operates most efficiently and trouble-free with cool, dry air circulation. Avoid locations near heat and moisture generating equipment such as stoves, ovens, cooking ranges, fryers, dish washers, steam kettles, etc., and also direct sunlight where temperatures can be in excess of 100 degrees f. Also, do not select a location in an unheated room or area where temperatures may drop below 55 degrees f. Air supply to the condensing unit is equally important. Restricting the air supply will place an excessive heat load on the condensing unit and adversely affect its operating efficiency.

Important Note: To assure maximum operating efficiency, your new model should be located where an unrestricted air supply can be circulated to the condensing unit. For optimum performance, **a minimum clearance of 3" on each side, front and back of the cabinet must be provided.** If necessary, special venting or air supply ducts must be installed by the installer for this purpose. Do not at any time obstruct the grill area in the front or rear of the cabinet in any way, and never place or store anything inside of the cabinet machine compartment. These rules are essential for maximum cooling capacity and long life of refrigeration parts.

FLOOR LOADS

The floor at the final location site must be level, free of vibration and strong enough to support the total combined weights of your new model plus the maximum product load which might be placed into it. A fully loaded bottle cooler may reach 2,000 pounds. To estimate the possible product load weight, assume that each cubic foot of storage space weighs approximately 35 pounds. Multiply 35 pounds by the amount of cubic feet in the cabinet and obtain the product load weight. For example, a 15 cubic foot bottle cooler can hold approximately 525 pounds of product (35 x 15) and assuming the refrigerator itself weighs 275 pounds, the total combined weight of cabinet and product is approximately 800 pounds. Therefore, the floor in this example must be capable of supporting up to 800 pounds.

MOUNTING EQUIPMENT IN PLACE

Your new horizontal bottle cooler is designed and constructed to be mounted directly on the floor without legs or casters (optional). When mounting directly to floor, the base of the cabinet should be sealed to the floor around its entire perimeter.

Important Note: It is extremely important that your new model is perfectly level for proper operation. If it is not level, the defrost water will fail to drain properly and will overflow the evaporator coil drain pan and into the cabinet of the model.

INSTALLING LEGS AND LEVELING

If you wish to install the optional legs on your new model, the legs will be supplied with adjustable type bullets for leveling purposes. Each CBC37, CBC50, and CBC64 model has four leg mounting holes on its case bottom, and CBC95 models have six leg mounting holes. Legs are packed in the accessory carton from which they must be removed and installed on the cabinet case bottom (see figure 1). In order to install the legs, carefully tip the cabinet rearward adding four (4) 2" wood blocks underneath and simply screw the threaded leg studs into the case bottom front leg holes. Repeat this procedure by tilting the cabinet in the opposite direction and install the remaining legs.

Make sure the legs are tightened extremely well or the entire model will sway or rock with each opening or closing of the lids, possibly causing damage to the case bottom. This procedure should be performed close to the final installation site and allow access

to the rear of the cabinet for condensate evaporator installation (see “condensate evaporator installation” under installation and location section).

To assure your cabinet is level, all legs are equipped with bullet-type leveling bolts. These bolts can be turned by hand or by wrench, clockwise or counterclockwise to level the cabinet.

Important note: two separate additional leg support plates are supplied with all CBC37 and CBC50 models purchased with the leg or caster option. These flat support plates must be mounted during installation of the legs or casters. Running one plate from right to left under the compressor compartment, sandwich the plate under the right front leg or caster and tighten, then thread one of the supplied skid bolts **with a washer** into the other hole on the cabinet bottom on the front left side of the compressor compartment and tighten. Do the same with the other plate for the right rear leg or caster. Now, install the left cabinet side legs or casters.

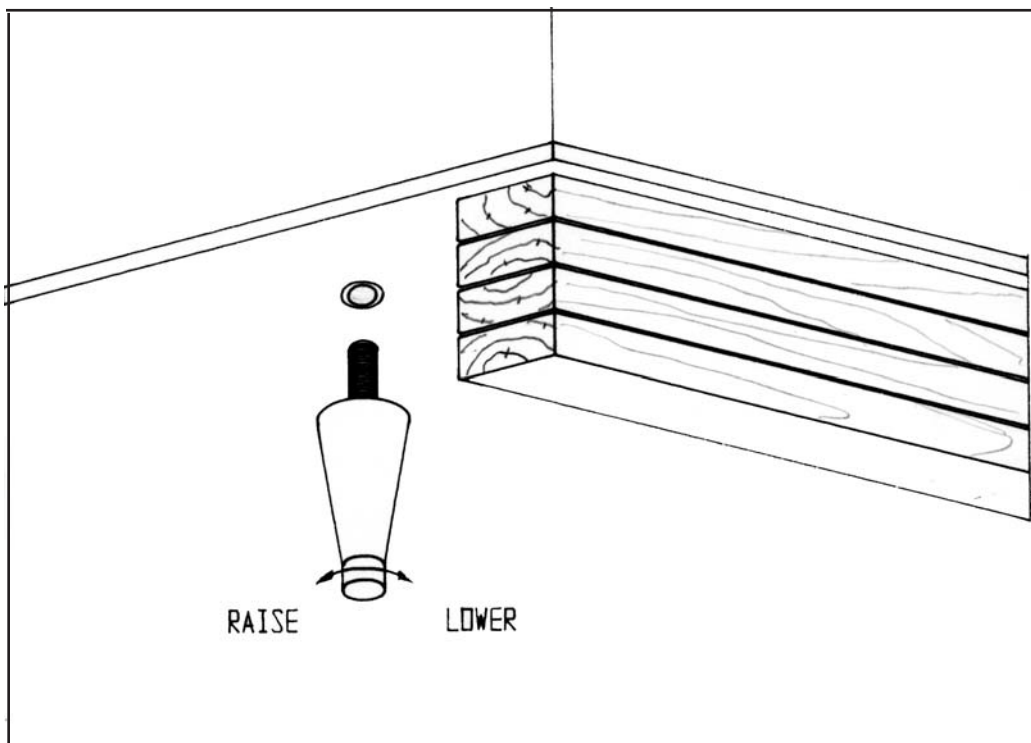

FIGURE 1
LEG INSTALLATION

Important Note: It is extremely important that your new model is perfectly level for proper operation. If it is not level, the defrost water will fail to drain properly and will overflow the evaporator coil drain pan and into the cabinet of the model.

INSTALLING CASTERS AND LEVELING

If you wish to install optional casters on your new model, follow the steps above for “installing legs” to install the casters, making sure again that the casters are tightened extremely well (see figure 2). If the casters are not installed tightly, the cabinet will sway or rock with each opening or closing of the lids, possibly causing damage to the case bottom.

To assure that your cabinet is level, caster cups must be installed under the casters which need leveling. Caster cups are not provided with your new model but can be purchased at most hardware or furniture stores. **Do not attempt to level casters by unscrewing them from the case bottom as this will cause damage to the cabinet bottom and leg hole threads, voiding all warranties.**

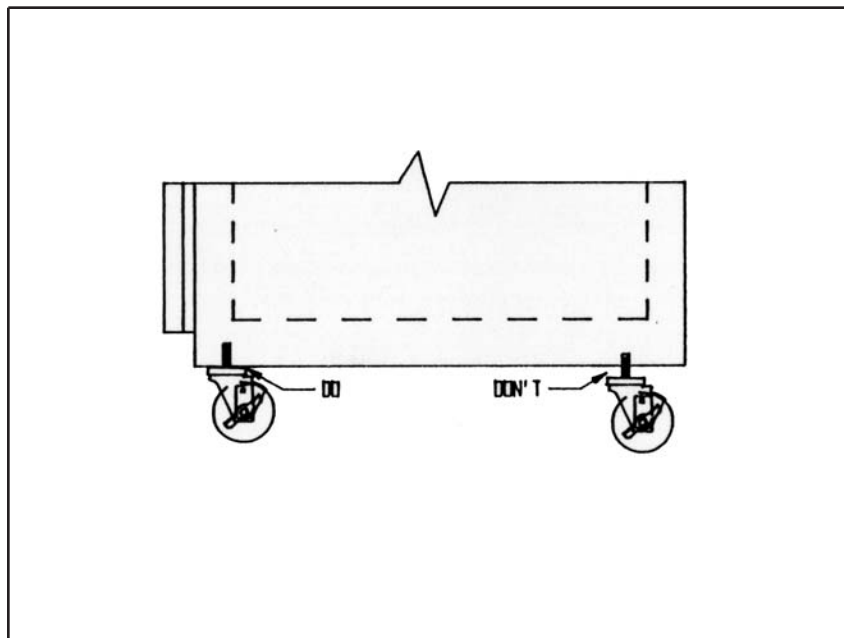

FIGURE 2
CASTERS MUST BE TIGHT TO CABINET BOTTOM

INSTALLING CONDENSATE EVAPORATOR

No floor drains or plumbing connections are required since all models use an automatic condensate water evaporating system. All *bottle cooler* models contain a factory installed condensate drain water evaporating pan which is completely self-contained and no further assembly or maintenance is required. For your convenience, only

evaporator condensate drains into this pan and cabinet washout drainage water has its own hose located behind the front grill for easy disposal during cabinet cleaning.

Important Note: Cabinet washout drainage hose can be accessed behind the front grill for easy disposal of water during cleaning.

INITIAL CLEANING PROCEDURE

Prior to start-up and before placing any bottles inside of your new model, the interior of the cabinet should be thoroughly cleaned. Washing with a mild soap and warm water solution is recommended for cleaning the galvanized and stainless steel surfaces of your cabinet. This should be followed by cleaning with a baking soda solution (three (3) tablespoons of baking soda to each quart of warm water). Rinse thoroughly with clear water and dry with a clean, soft cloth.

Important Note: Never use harsh detergents, cleaners, scouring powders or chemicals when cleaning your model. Failure to dry the interior surfaces after cleaning may result in a streaking or staining of the metal.

Complete cleaning procedures and precautions are listed in the “periodic cleaning procedure” under the maintenance section.

START-UP PROCEDURE **ELECTRICAL CONNECTIONS**

To insure proper operation, your new model must be connected to an individual circuit that can supply the full voltage as stated on the cabinet serial data plate. For correct voltage, power draw, and wire accommodations, check the data on the serial data plate located on the inner right wall of your new model. Verify that this information exactly matches the electrical characteristics at the installation location. An electrical wiring diagram, located on the inside compressor compartment end panel next to the electrical console box, should also be consulted during connection. For reference, a copy of the electrical wiring diagram is located at the rear of this manual.

Important Note: The condensing unit supplied with all self-contained models is designed to operate with a voltage fluctuation of $\pm 10\%$ of the voltage indicated on the cabinet serial data plate. Full voltage of the correct service, on an individual line not affected by the operation of other electrical appliances, must be available to the condensing unit at all times. **Burnout of the compressor due to exceeding the high or low voltage limits is easily detected and will automatically void the factory warranty.**

115 VOLT, 60 HZ, 1 PHASE CONNECTION

All 115 volt models are provided with a U.L. approved power cord and polarized plug which is factory installed.

Warning: any alterations to this cord and plug could cause an electrical hazard and will void the factory warranty.

To insure proper operation, this equipment must be plugged into a NEMA 5-15R compatible, grounded receptacle that can supply the full voltage as stated on the serial data plate.

208-230 VOLT, 60 HZ, 1 PHASE CONNECTION

All 208-230 volt models are to be permanently connected and are provided with four (4) field wiring leads which exit the electrical console box located in the machine compartment behind the rear grill. The cabinet circuitry is 115 volts and the condensing unit is 208-230 volts in which the wiring includes a neutral and a mechanical ground. This wiring should be connected to the appropriate power source by a qualified electrician and must conform to all local electrical codes.

SPECIAL VOLTAGE CONNECTIONS

When models are ordered from the factory with special, optional voltages, connections should be made as required on the electrical wiring diagram provided on the inside compressor compartment end panel next to the electrical console box.

START-UP CHECKLIST

After your model has been installed, leveled, cleaned, and electrically connected in accordance with this manual, please take the time before start-up to observe the following precautions to assure trouble-free operation:

1. Check that all exposed refrigeration lines are free of severe dents or kinks.
2. Check the condenser fan and evaporator fans for freedom to rotate without any obstructions
3. Make sure that the cabinet is properly leveled (see "leveling" under installation and location section).

The system should run smoothly and quietly in accordance with generally accepted commercial standards. If any unusual noises are heard, turn the unit off immediately and check for any obstructions of the condenser or evaporator fans. Fan motors, fan blades, or fan housings can be jarred out of position through rough handling in transit or during installation.

Caution: if unit is unplugged or disconnected for any reason, allow several minutes (5-6 minutes) before turning the unit back on to allow the system pressures to equalize. Disregarding this procedure could cause an overload and prevent the unit from operating.

REMOTE APPLICATIONS

All models are available for purchase as remote models in which case the condensing unit is purchased separately and installed at the time of installation. All remote models are equipped with an expansion valve located within the evaporator coil housing, and both liquid and suction lines stubbed and extending out from the cabinet condensing unit compartment behind the front and rear grill. Installation of the refrigeration accessories, condensing unit, and electrical hook-up should be performed by qualified refrigeration personnel of a competent refrigeration company only.

OPERATION

All cabinets must be given sufficient time to reach normal operating temperature before placing any product inside. Refrigerated bottle coolers are designed to maintain an ideal cabinet temperature of 34°F to 38°F (1.1°C to 3.3°C) and approximately 3 hours of operation are required to reach this temperature.

REFRIGERATOR SYSTEM AND ADJUSTMENT

All self-contained *bottle* cooler refrigerators are designed and factory set to maintain an average cabinet temperature of 36°F. The temperature control is accessible inside of the cabinet product compartment, on the right back wall next to the evaporator coil. See figure 3 for thermostat location. If an adjustment is necessary to maintain the above temperature range **only**, place a screwdriver into the thermostat slot and turn clockwise for a colder cabinet temperature or counterclockwise for a warmer cabinet temperature. Further adjustments out of the factory design temperature range must be made by a qualified refrigeration mechanic only.

Important Note: All refrigerators are designed with an automatic; “off-cycle” defrost system which means that defrosting occurs automatically when the compressor is not operating during an off-cycle. **Do not** set the thermostat too cold where the cabinet temperature will fall below 33°F because the evaporator will become blocked by ice since the compressor off-cycle will be considerably shortened. This will result in loss of food stored within the cabinet and require service to defrost the evaporator and re-adjust the thermostat.

EVAPORATOR ASSEMBLY

All *continental bottle cooler* refrigerators have an easily accessible, easily serviceable, performance rated, forced-air evaporator assembly which utilizes a plasticized fin coil for extended life. All models utilize a full length, extra large evaporator coil which provides uniform air flow distribution for quick top row product chilling. The evaporator assembly system is shown in figure 3.

Warning: Do not place hands up and under fan motor housing during operation since fan blade is located here.

INTERIOR AND EXTERIOR ACCESSORIES

The standard accessory package that is supplied from the factory with your new *continental bottle cooler* consists of one (1) small wire storage bin divider for all models, one (1) large wire storage bin divider for CBC37 models, two (2) large wire storage bin dividers for CBC50 models, three (3) large wire storage bin dividers for CBC64 models, and seven (7) large wire storage bin dividers for CBC95 models. All wire bin dividers come with mounting springs (one per bin divider). Also enclosed is a bottle cap opener and bottle cap catcher assembly (CBC95 models contain two assemblies).

BOTTLE CAP CATCHER INSTALLATION

To attach the bottle cap catcher assembly to the front of the cabinet, loosen the two exposed mounting screws above the grill assembly and simply hang the bottle cap catcher on the screws using the provided key-slot holes. To remove the bottle cap catcher for emptying or cleaning, just lift up and pull the catcher towards you.

WIRE STORAGE BIN DIVIDER INSTALLATION

Install the small wire bin divider first by inserting mounting spring over the long extension as shown in figure 3, and then pushing the long extension into any one of the six fan cover bushing holes. **Be sure to disconnect power when installing or removing the small wire bin divider only - fan may interfere with long extension causing damage to your model.**

Now, push the bin divider towards the rear of the cabinet compressing the mounting spring almost all of the way and insert the front of the bin divider into its respective hole location in the interior cabinet front. The mounting spring will keep the wire bin divider in place and power can now be restored to your model. The large wire bin dividers can now be installed in the same manner as the small bin dividers but, in their respective holes as shown in figure 3.

Important Warning: **Always disconnect the power to your bottle cooler when installing or removing the small wire bin divider since the long extension on the bin divider may interfere with the fan and damage could result to your bottle cooler causing your warranty to become null and void.**

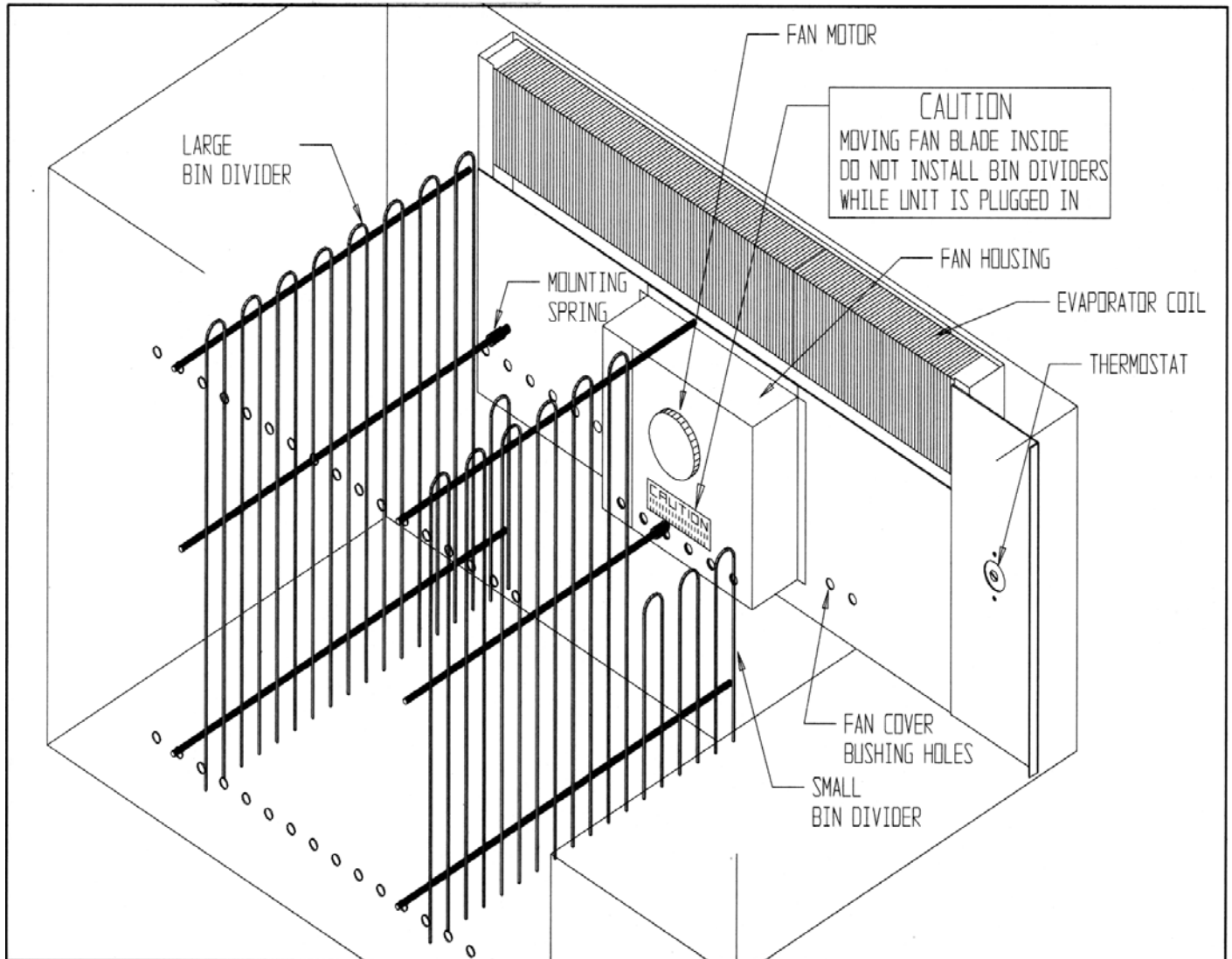

FIGURE 3
EVAPORATOR ASSEMBLY AND STORAGE BIN DIVIDER INSTALLATION

KEG COOLER SET-UP & INSTALLATION INSTRUCTIONS

(Refer to drawing on next page)

INSTALLATION OF TOWERS AND COLD AIR TUBES

To install cooling tower(s), place rubber washer over tower mounting holes in cabinet top and secure tower(s) onto top using fine thread machine screws supplied on cabinet

top (do not use wood screws supplied with tower). Beer line from tower must go through hole in top and attaches to keg tap (not supplied).

The cold air tubes coming from the grill inside of the cabinet can be installed by simply pushing each tube as far as it will go into its closest tower hole. About eight inches of tube will feed into the tower.

INSTALLATION OF CO₂ CYLINDER AND REGULATOR

A CO₂ tank up to five pounds in size (not supplied) may be placed inside the cabinet on the step or removed outside of the cabinet. If removed outside of cabinet, a knock-out plug on the step floor is provided for convenience for the CO₂ hose. The CO₂ dispensing gas must be reduced to an 8-10 PSI by a regulator (not supplied). The regulated gas must be delivered to the manifold splitter (located on the left upper wall of cabinet) using the supplied hose and clamps. Size and cut hose as necessary. The manifold splitter will separate the gas into two or more lines to supply gas to each keg tap. A check valve is installed on the manifold splitter to prevent beer from backing up into the supply hose and regulator.

KEG TAPPING INSTRUCTIONS

Because keg and tap types vary from brand to brand, contact your beer distributor for specific keg tapping instructions.

Important Notes: For your convenience, a beer spillage and clean out drain hose has been provided and is located behind the front grill. Approximately 3 ft of hose is supplied for an external drainage connection to be made by installer. The drain line (located on the left front interior floor) can be cut if a beer waste jar is desired for interior installation.

Defrosting is automatic but because door openings for loading can vary in time it is recommended that the unit be unplugged with the doors left open for at least fifteen minutes during the keg changing.

The thermostat control (located on the left rear interior of cabinet) is factory set to maintain your beer keg temperatures within the most desirable range of 35° F to 40° F under normal conditions. It may take several hours to cool a warm keg so it is important to install cold purchased kegs inside the cooler immediately to avoid warm-up of beer. Before a new barrel is tapped, the CO₂ lines should be purged by quickly opening and closing the regulator outlet valve, allowing a surge of gas to travel through the line and tap.

Proper cleaning is extremely important for the beer faucet, drain pan or any item coming in contact with food or beverages to prevent odors and tastes from bacteria. It is normal for some sweating to occur on or around each draft tower, and around door openings under conditions of high humidity

TYPICAL "KC" FEATURES & SET-UP GUIDE

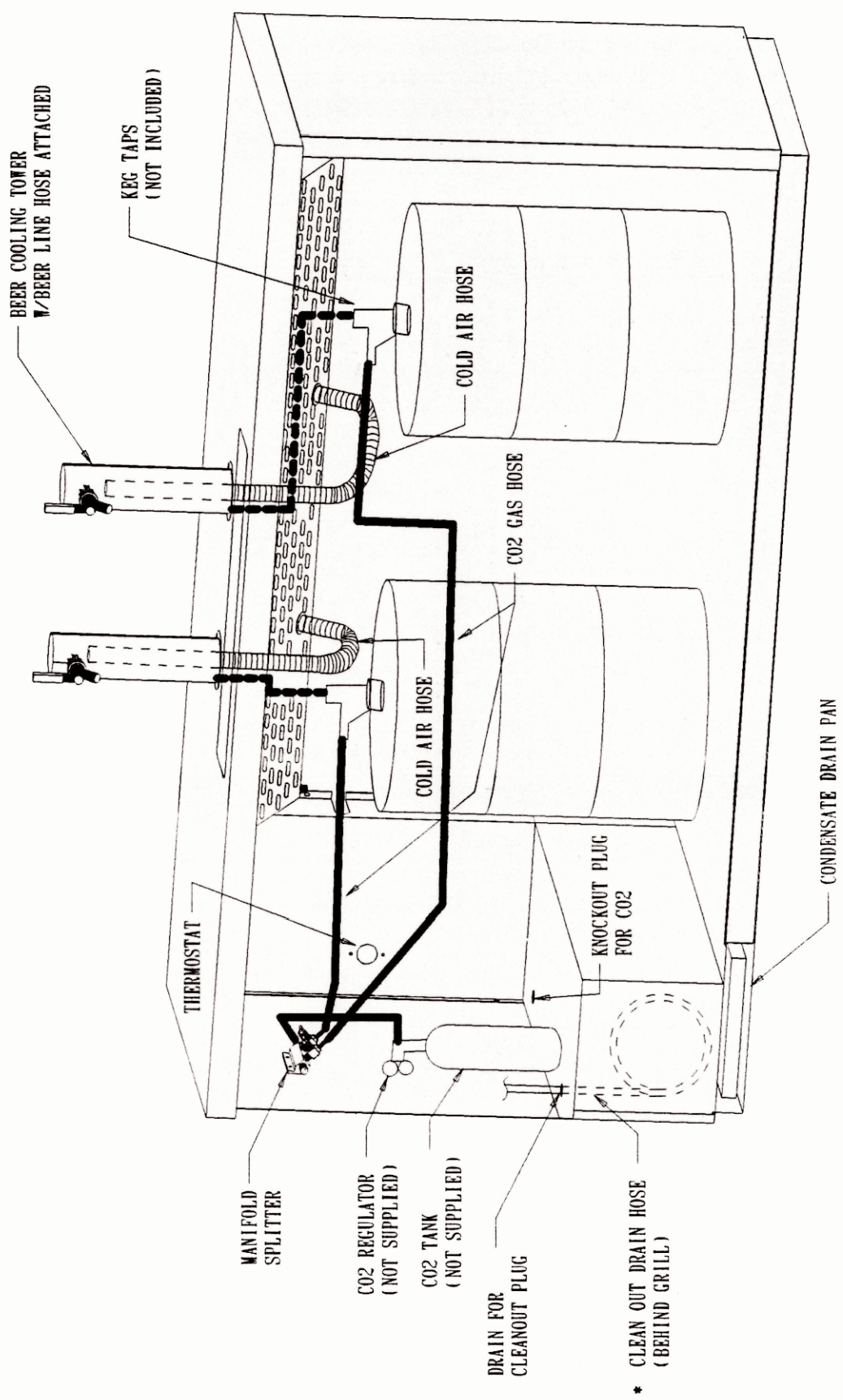

* CLEAN OUT DRAIN HOSE
(BEHIND GRILL)

* CLEANOUT DRAIN HOSE LOCATED BEHIND FRONT GRILL
MUST BE CONNECTED TO A FLOOR DRAIN BY INSTALLER

SAFETY PRECAUTIONS

The following safety precautions should be followed when operating any appliances:

- ★ Always disconnect the power cord before attempting to work on or clean any equipment.
- ★ Disconnect the power cord when the appliance will be idled for a long period of time.
- ★ Do not attempt to service this unit yourself as removing any covers may cause exposure to dangerous voltage.
- ★ Always route the power cord so that it is not likely to be walked on or pinched by other appliances. Never use extension cords.
- ★ Do not overload outlets with more than one appliance. This can result in fire or electrical-shock
- ★ Your model is equipped with a grounded and polarized plug. Do not defeat the purpose of this plug by removing the ground post or using a non-polarized adapter without properly grounding the outlet.

Never connect any appliance to a power source while standing in water or with wet hands.

When a replacement part is required, always insist on factory authorized parts only.

MAINTENANCE

PERIODIC CLEANING PROCEDURE

It is best to clean your *continental bottle cooler* when the product load is at its lowest level inside your cabinet. To clean the interior or exterior cabinet surfaces, the following procedure should be followed:

1. Disconnect your model from its power supply and remove all product from inside.
2. Open all doors and allow the cabinet to reach room temperature. Remove all accessories (shelves, racks, pilasters, clips, etc.) from within the model, wash with a baking soda and warm water solution, and rinse thoroughly with clear water. Dry all of the accessories completely with a soft clean cloth.
3. Once the cabinet has reached room temperature, wash the entire cabinet inside and out with a baking soda and warm water solution. For slightly more difficult cleanups, ammonia or vinegar in warm water can be used. Rinse thoroughly with clear water and dry with a soft clean cloth. Failure to dry all surfaces completely may cause water stains or streaking on the aluminum or stainless steel finish.
4. Return all accessories to their respective positions and return electric supply power to the model.

PRECAUTIONS

1. Never use harsh detergents, cleaners, scouring powders, or chemicals when cleaning your model.
2. Strong bleaches tend to corrode many materials and should never come in contact with stainless steel.
3. Tincture of iodine, or iron should not come in contact with stainless steel. These solutions, which cause stainless steel to discolor, should be rinsed off immediately if contact occurs.
4. Gritty, hard abrasives will mar the finish of stainless steel and aluminum and are not recommended.

GENERAL PREVENTATIVE MAINTENANCE

Performance of the air cooled condensing unit located on the bottom of your new model, depends exclusively upon the amount of air passing through the condenser fins. Your refrigerator will run more efficiently, consume less current, and provide a maximum of trouble-free service throughout its lifetime if the condenser is kept clean and an adequate supply of clean, cool air is provided at all times. Periodically (at least once a month) inspect the condenser coil, which is located directly behind the front grill, to check for debris or blockage.

If the condenser coil is dirty or blocked, disconnect the power supply to your model and using a stiff brush, brush the dirt from the condenser fins until the condenser is clear from any debris. Using a vacuum cleaner with a brush attachment may aid in this cleaning process. After cleaning, restore electrical service to your model.

PARTS AND SERVICE

Always provide the cabinet model and serial number (located on the data plate on the inside right wall of the cabinet) whenever contacting the factory or your dealer regarding questions or when ordering parts.

TROUBLESHOOTING AND SERVICING GUIDE

PROBLEM	PROBABLE CAUSE	CORRECTION
Condensing unit will not start - no hum.	<ol style="list-style-type: none"> 1.Line Disconnected, Switch Open. 2.Fuse Removed Or Blown. 3.Overload Protector Blown. 4.Control "Off" Due To Cold Location. 5.Control Stuck In Open Position. 6.Wiring Improper Or Loose 	<ol style="list-style-type: none"> 1.Close Start Or Disconnect Switch. 2.Replace Fuse. 3.Determine Reason And Correct/Replace. 4.Relocate Control. 5.Repair Or Replace Control. 6.Check Wiring Against Diagram.
Condensing unit will not start - hums but trips on overload protector.	<ol style="list-style-type: none"> 1.Improperly Wired. 2.Low Voltage To Unit. 3.Starting Capacitor Defective. 4.Relay Failing To Close. 5.Compressor Motor Has A Shorted Or Open Winding. 6.Internal Mechanical Trouble In Compressor. 7.Insufficient Air Supply. 	<ol style="list-style-type: none"> 1.Check Wiring Against Diagram. 2.Determine Reason And Correct. 3.Determine Reason And Replace. 4.Determine Reason And Replace. 5.Replace Compressor. 6.Replace Compressor. 7.Clean Condenser & Allow Compressor To Cool Down.
Condensing unit starts and runs, but short cycles on overload protector.	<ol style="list-style-type: none"> 1.Additional Current Passing Through Overload Protector. 2.Low Voltage To Unit 3.Overload Protector Defective. 4.Run Capacitor Defective. 5.Excessive Discharge Pressure. 6.Excessive Suction Pressure. 7.Insufficient Air Supply 	<ol style="list-style-type: none"> 1.Check Wire Diagram Check For Added Components Connected To Wrong Side Of Overload Protector. 2.Determine Reason And Correct. 3.Check Current, Replace Protector. 4.Determine Reason And Replace. 5.Check Ventilation, Restrictions In Cooling Medium Or Refrig. System. 6.Check For Misapplication. 7.Clear Condenser & Allow Compressor To Cool Down.
Condensing unit starts, but fails to switch off of "start" winding.	<ol style="list-style-type: none"> 1.Improperly Wired. 2.Low Voltage To Unit. 3.Relay Failing To Open. 4.Run Capacitor Defective. 5.Excessively High Discharge Pressure. 6.Compressor Motor Has A Shorted Or Open Winding. 7.Internal Mechanical Trouble In Compressor. 	<ol style="list-style-type: none"> 1.Check Wiring Against Diagram. 2.Determine Reason And Correct. 3.Determine Reason And Replace. 4.Determine Reason And Replace. 5.Check Discharge Shut-Off Valve, Possible Overcharge. 6.Replace Compressor. 7.Replace Compressor.

PROBLEM	PROBABLE CAUSE	CORRECTION
Condensing units runs but short cycles on:	1. Overload Protector. 2. Thermostat. 3. High Pressure Cut-Off Due To: (a) Insufficient Air Supply. (b) Overcharge. (c) Air In System. 4. Low Pressure Cut-Off Due To: (a) Valve Leak. (b) Undercharge (c) Restriction In Expansion Device.	1. See Problem # 3. 2. Differential Must Be Widened. 3. (a) Check Air Supply To Condenser. (b) Evacuate And Re-Charge. (c) Evacuate And Re-Charge. 4. (a) Replace, Evacuate, And Re-Charge. (b) Evacuate And Recharge (c) Replace Expansion Device.
Condensing unit runs but for prolonged periods or continuous.	1. Shortage Of Refrigerant. 2. Control Contacts Stuck Closed. 3. Excessive Heat Load Placed Into Cabinet. 4. Prolonged Or Too Frequent Door Opens. 5. Evaporator Coil Iced. 6. Restriction In Refrigeration System. 7. Dirty Condenser. 8. Filter Drier Clogged.	1. Fix Leak, Evacuate And Recharge. 2. Clean Contacts Or Replace Control. 3. Allow Unit Sufficient Time For Removal Of Latent Heat. 4. Plan Or Organize Schedule To Correct Condition. 5. Defrost Evaporator Coil. 6. Determine Location And Remove 7. Clean Condenser Coil. 8. Replace, Evacuate And Re-charge.
Start capacitor open, shorted or blown.	1. Relay Contact Not Opened Properly 2. Prolonged Operation On Start Cycle: (a) Low Voltage To Unit. (b) Improper Relay. (c) Starting Load Too High. 3. Excessive Short Cycling. 4. Improper Capacitor.	1. Clean Contacts Or Replace Relay. 2. (a) Determine Reason And Correct. (b) Replace With Correct Relay. (c) Correct By Using Pump Down. 3. Determine Reason For Short Cycle (See Problem #5) And Correct. 4. Determine Correct Size And Replace.
Run capacitor open, shorted or blown.	1. Improper Relay 2. Excessively High Line Voltage, Over 110% Of Rated Maximum.	1. Check Size And Replace. 2. Determine Reason And Correct.
Relay defective or blown out.	1. Incorrect Relay 2. Incorrect Mounting Angle. 3. Voltage Too Low Or Too High. 4. Excessive Short Cycle. 5. Loose Or Vibrating Mounting Position. 6. Incorrect Run Capacitor. 7. Loose Wiring On Relay Or Overload	1. Check Relay And Replace. 2. Remount Relay In Correct Position 3. Determine Reason And Correct. 4. Determine Reason And Correct (See Problem # 5) 5. Remount Rigidly. 6. Replace With Proper Capacitor. 7. Tighten All Wiring Screws.

PROBLEM	PROBABLE CAUSE	CORRECTION
Product zone tempature too high.	<ol style="list-style-type: none"> 1.Control Setting Too High. 2.Inadequate Air Circulation. 3.Dirty Condenser 	<ol style="list-style-type: none"> 1.Evacuate And Re-Charge. 2.Rearrange Product Load To Improve Air Circulation. 3.Clean Condenser Coil
Suction line frosted or sweating.	<ol style="list-style-type: none"> 1.Overcharge Of Refrigerant 2.Evaporator Fan Not Running. 3.Expansion Valve Stuck Open. 4.Expansion Valve Superheat Too Low. 	<ol style="list-style-type: none"> 1.Evacuate And Re-Charge. 2.Determine Reason And Correct. 3.Clean Valve, Evacuate And Re-Charge. 4.Adjust Superheat To Required Setting.
Liquid line frosted, cold, or sweating.	<ol style="list-style-type: none"> 1.Restriction In Drier Strainer. 2.Liquid Line Service Valve Partially Closed. 	<ol style="list-style-type: none"> 1.Replace Drier, Evacuate And Recharge. 2.Open Valve Fully Or Replace If Necessary.
Noisy condensing unit.	<ol style="list-style-type: none"> 1.Loose Parts Or Mountings. 2.Tubing Rattle Or Vibration. 3.Bent Fan Blade Causing Excessive Vibration. 4.Fan Motor Bearings Worn. 	<ol style="list-style-type: none"> 1.Tighten All Mounting Parts And Shroud Cover. 2.Reform Tubing To Be Free Of Contact. 3.Replace Fan Blade. 4.Replace Fan Motor.
Thermometer reads different than actual tempature.	<ol style="list-style-type: none"> 1.Calibration 2.Defective 	<ol style="list-style-type: none"> 1.Consult Operations Manual And Calibrate. 2.Relace.
Water leak inside unit.	<ol style="list-style-type: none"> 1.Condensate Drain Pan Not Installed Properly. 2.Unit Not Level. 3.Drain Pan Misaligned. 4.Defective Drain Pan 	<ol style="list-style-type: none"> 1.Consult Operation Manual And Calibrate. 2.Make Sure Unit Is Level Or Pitched Back Slightly . 3.Make Sure Drain Pan Is Aligned Properly. 4.Replace.
Doors Misaligned.	<ol style="list-style-type: none"> 1.Shifted During Shipping 	<ol style="list-style-type: none"> 1.Refer To Operation Manual For Hinge Adjustment.

WIRING DIAGRAMS

SELF-CONTAINED UNDERCOUNTER REFRIGERATOR WD-R5 115/60/1

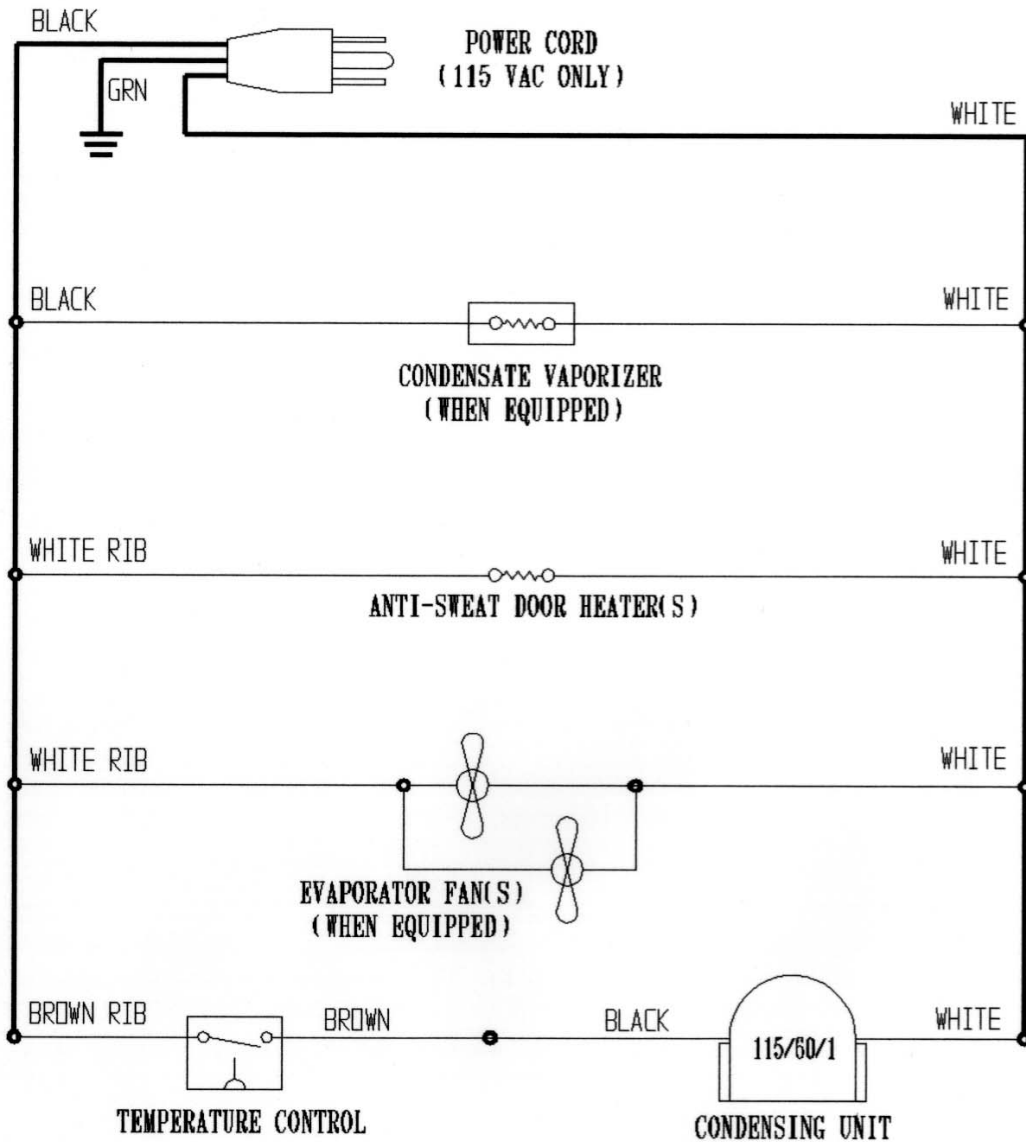

Continental REFRIGERATOR
A Division of National Refrigeration & A/C Products, Inc.

SELF-CONTAINED UNDERCOUNTER FREEZER WD-F5 115/60/1

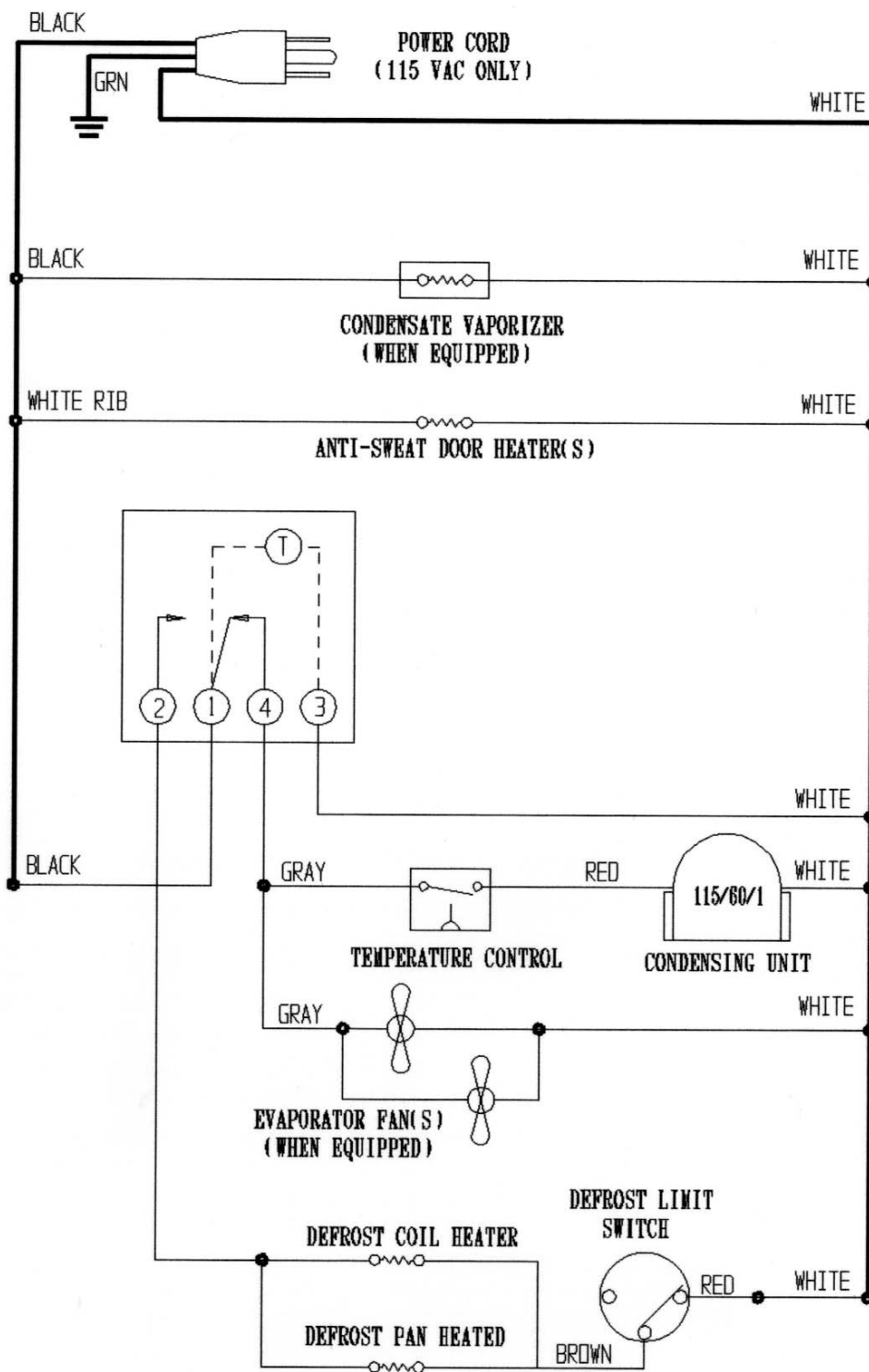

Continental REFRIGERATOR
A Division of National Refrigeration & A/C Products, Inc.



Continental Warranty Procedure

Continental's warranty is 1 year on parts and labor, and 5 years on the compressor, from the date of original installation on any unit.

Please consult the factory before any warranty service work is completed. **Exceptions will be made.** For example; after hours, you must contact the factory at 1-800-523-7138 at extension 113 or 134. You **MUST** provide the model and **serial number**, place of business, where the unit is located and if possible the installation date. Contact the factory the following business day, during normal business hours 8 A.M. to 5 P.M. eastern time, to follow up with Continental's service department.

The customer has the freedom of using any certified technician for the warranty service. The service company's information, such as, name, address, phone and fax numbers, must be provided. The invoice may be faxed or mailed to the address listed below for payment; however, Continental has the right to contact the service company with questions on any unnecessary, excessive charges.

Not all items are covered under warranty, such as, temperature adjustments, calibration, leveling, dirty condensers, any preventive maintenance and any misapplication i.e. not enough ventilation.

Please consult the factory for any parts or questions regarding the above warranty procedures.

Thank You,
Parts and Service

Continental

Refrigerator

Warranty Compressor Procedures

If the compressor fails within the first (12) months of use or (20) months by the date code on the compressor, an “over-the-counter exchange” must be made through a Tecumseh or Copeland dealer.

After the first year the additional (4) year compressor warranty is through Continental Refrigeration, and can be handled by one of the following methods:

- (1) Continental will supply the replacement compressor at no charge and pay for regular ground freight.
- (2) Continental will supply the compressor at no charge and the end user, dealer or service company pays for the freight, other than regular ground (COD, Visa or Mastercard).
- (3) A compressor can be purchased locally and Continental will either replace the compressor for stock or offer an allowance towards its purchase. The end user is to pay the difference:

- (A) $\frac{1}{5}$ h.p. to $\frac{1}{3}$ h.p.-Up to \$100
- (B) $\frac{1}{2}$ h.p. to $\frac{3}{4}$ h.p.-Up to \$250
- (C) 1 h.p. to 2 h.p.-Up to \$350

Exceptions will be made depending on circumstances, but in all cases, Continental must be notified prior to any transaction, if possible. The tag from the defective compressor or the information (if unable to remove) must be returned for proof of failure after the first year. Please contact the service department with any further questions.

Thank You,
The Service Department

Continental

Refrigerator

Items NOT Covered Under Warranty:

**Consult your owner's manual for detailed information on the following:
(page #'s listed beside each line item).**

- I. Preventative Maintenance
 - A. Dirty Condenser (13-14)
 - B. General Hardware Adjustments
 - 1. Casters/Legs (3-5)
 - 2. Handles
 - 3. Hinges
 - 4. Light Bulb Replacement
- II. Compressor Failure Due to Poor Air Circulation
 - A. Reach-In, Roll-In Models, Warmers (White)*
 - 1. 12" Above Grill Area (2-3)
 - 2. 3" On Sides, Back & Underneath (Reach-In only) (2-3)
 - B. Backbar, Keg, Bottle Cooler Units & Glass, Plate Chiller Units (Green)*
 - 1. 3" On Sides & Back (2-3)
 - C. Undercounter, Sandwich & Pizza Prep Units (Yellow)*
 - 1. 3" On Sides, Back & Underneath (2-4)
 - D. Front Breather Units (Yellow)*
 - 1. Minimal Ventilation Needed
- III. Temperature Adjustments / Calibrations (8)
- IV. Leveling (3-5)

**** FAILURES DUE TO LACK OF MAINTENANCE, POOR INSTALLATION OR INAPPROPRIATE OPERATION OF THE UNIT MAY VOID CUSTOMER'S WARRANTY****

Please contact the Service Dept. with any questions pertaining to the above.

**Thank You,
The Service Dept.**

***Color of owner's manual.**