



60" SELF-CONTAINED BACK BAR REFRIGERATOR
2-Door Model



eco friendly
 R290 Hydrocarbon Refrigerant

JOB
AREA
ITEM NO.
MODEL NO.

Model
BBS60-SS-L-STK



BBS60-SS-L-STK

KEY PRODUCT FEATURES AND BENEFITS

- Stainless steel interior and top standard on all Perlick back bar refrigeration for long life durability and easy to clean hygienic storage
- 2" foamed-in-place eco-friendly insulation provides energy savings with zero ozone depletion
- NSF/ANSI Standard 7 Listed for open food, beverage, and garnish storage
- End wall compressor and evaporator design increases storage capacity by 14% compared to top mounted designs
- Anti-sweat heaters prevent condensation from forming, extending door gasket life and protecting flooring below from damage or slip hazards

Quick Features

- Integrated door and drawer locks standard on all units
- Refrigerator temperature range 34-42F°, factory set to 38F°
- NSF rated digital controller allows for easy and precise temperature changes
- 1 Year Parts and Labor Warranty, 5 Year Compressor Warranty
- Made in USA



60" SELF-CONTAINED BACK BAR REFRIGERATOR
2-Door Model

MODEL NUMBERS		BBS60-SS-L-STK
NUMBER OF COMPARTMENTS/DOORS		2
EXTERIOR CABINET DIMENSIONS	Length - in. (mm)	60 (1524)
	Depth - in. (mm)	24¾ (629)
	Height - in. (mm)	34⅞ (878)
INTERIOR CABINET DIMENSIONS	Length - in. (mm)	44 (1118)
	Depth - in. (mm)	18¾ (476)
	Height - in. (mm)	28½ (724)
INTERNAL VOLUME Net. Cu. Ft. (Litres)		16 (453)
PRODUCT CAPACITY	CASE PACK - 12 OZ. BOTTLE/CAN	371/553
	STAGGERED - 12 OZ. BOTTLE/CAN	400/592
SHIPPING WEIGHT Lbs. (kg.)		340 (154k)
ELECTRICAL SPECIFICATIONS	Electrical Supply	120 VAC/60 Hz/1 Ph
	Running Load Amps	2.5
	Electrical Connection	Cord connected
	Cord Plug Type	NEMA 5-15
	Cord Length	6'5"
	Defrost Initiation	Automatic
	Defrost Type	Off cycle
	Thermostat	Digital control
	Lighting Type	LED
REFRIGERATION SPECIFICATIONS	Horsepower	1/5
	Refrigerant	R290
	Refrigerant Charge (grams)	100
	Total Heat Rejection at 75F ambient (BTU/hr)	1900
	Factory Temperature Setting - Refrigerator F (C)	38° (3.3°)
	Temperature Range - Refrigerator F (C)	33°-40° (0.5°-4.5°)
	Condensing Unit Location	Left or Right
	Expansion Device	Capillary tube
	Pull-Out Condensing Unit	Yes
	Front Vented	Yes
PLUMBING		None required

! WARNING: California Prop 65 Notice

These products may expose you to chemicals including Chromium, which are known to the state of California to cause cancer and birth defects or other reproductive harm. For more information on whether a product in this list contains these chemicals, please refer to the specific product page at perlick.com. Or to find out more about Prop 65, go to P65Warnings.ca.gov.

Form No. Z2907
 Rev. 06.22.2023



60" SELF-CONTAINED BACK BAR REFRIGERATOR
2-Door Model

Note: Open floor drain not provided on models intended for non-packaged food.
 Maximum of 2 drawer compartments available on BBS84 and BBS108 models. Three drawer compartments shown only for dimensional purposes.

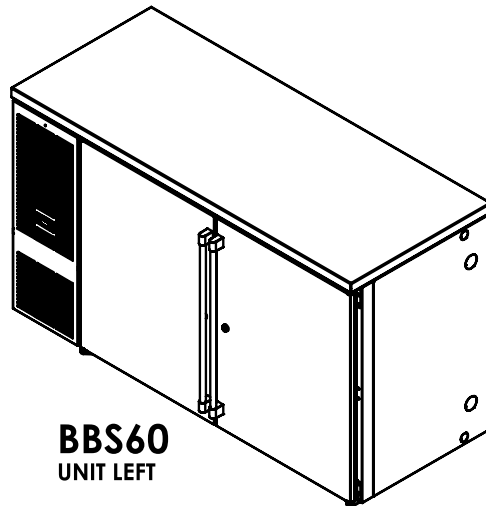

BBS60
UNIT LEFT

