



031123
WDB600 Base Unit

Unit Information

60Hz – 1800 Watts
 Large Burner - 1300 Watts
 Small Burner - 500 Watts

Temperature Settings
 1 - Low • 2 - Low/Medium
 3 - Medium • 4 - Medium/High
 5 - High

WDB600
Double Burner

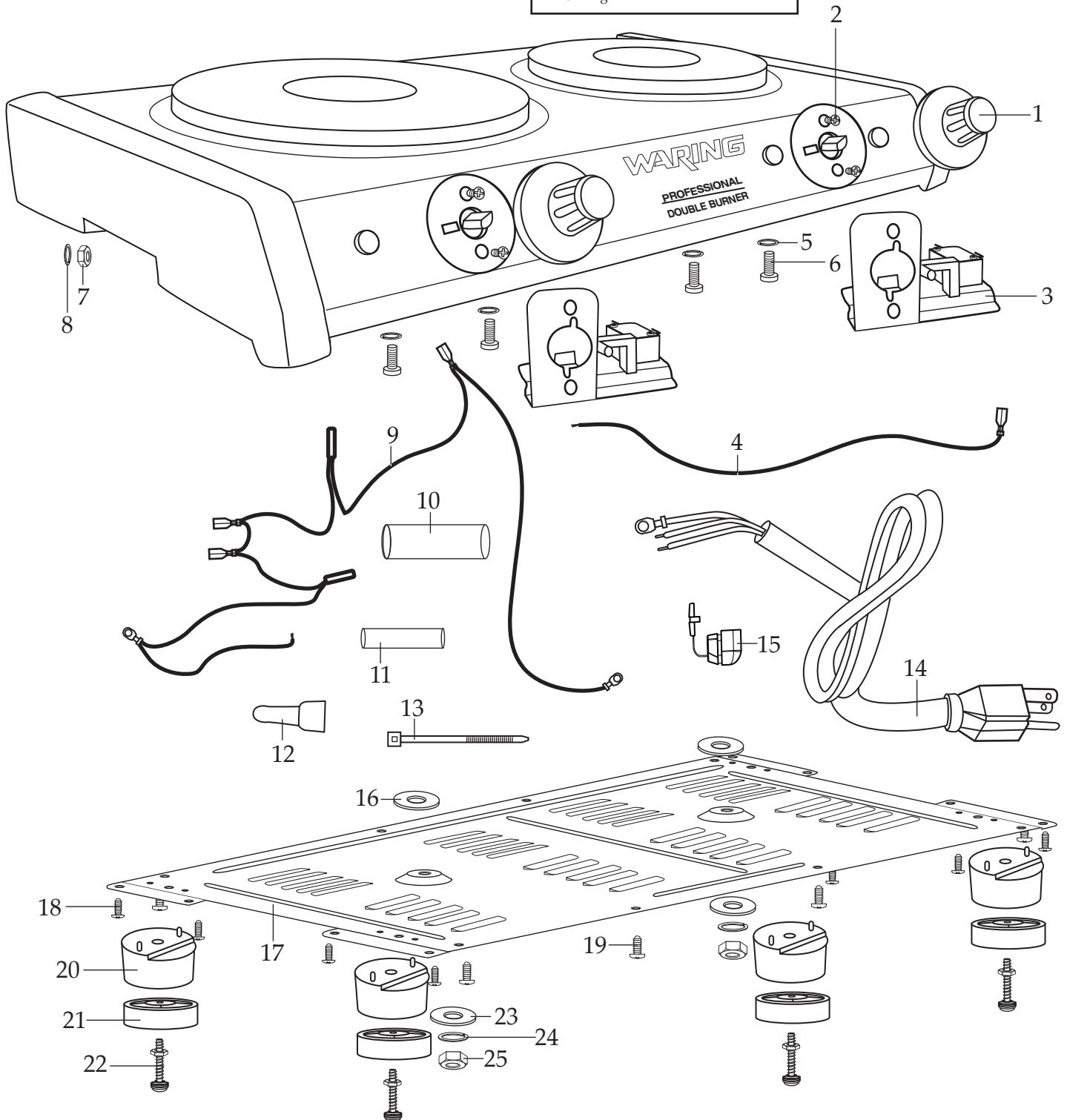

Illustration #	Part #	Description
1	031098	Knob (2 required)
2	031009	Screw (4 required)
3	031100	Bracket with Micro Switch (2 required)
4	031125 031126	22" Red Lead (small burner side) 44" Red Lead (large burner side)
5	031118	Heating Element Spring Washer (4 required)
6	031117	Heating Element Screw (4 required)
7	031115	Ground Lead Nut
8	031116	Ground Lead Spring Washer
9	031127 031128	7 Lead Set (small burner side) 7 Lead Set (large burner side)
10	031124	Connector Sleeve (2 required)
11	031113	Lead Sleeve (4 required)
12	019123	Crimp Connector (2 required)
13	013731	Wire Ties (9 required)
14	031104	Cord
15	031103	Strain Relief
16	031112	Center Burner Shaft Washer (before bottom plate 2 required)
17	031129	Bottom Plate
18	031108	Screw (8 required)
19	031109	Screw (8 required)
20	031120	Plastic Feet (4 required)
21	031106	Rubber Feet (4 required)
22	031107	Screw & Washer Set (4 required comes with screw, 3 washers, 1 spring washer and 1 nut)
23	031112	Center Burner Shaft Washer (after bottom plate 2 required)
24	031111	Center Burner Shaft Spring Washer (after bottom plate 2 required)
25	031110	Center Burner Shaft Nut (after bottom plate 2 required)

